

ACCIDENT DETECTION & ALERTING SYSTEM

Jazim Baramy , Pragma Singh , Aryasheel Jadhav , Krutikesh Javir, Ms. Sonali Tarleka*,

Department Of Electronics & Telecommunication

Ramrao Adik Institute Of Technology, Nerul

Navi Mumbai, India

sonutarlekar@gmail.com

Abstract- Security in travelling is a primary concern for everyone. Rising demand for automobile has increased the traffic, thereby causing more accidents on the road. People often lose their lives because of poor emergency facilities in the case of unattended accidents. Pre-emption of the accidents taking place on the roads is not possible but at least the after effects can be minimized. The proposed system ensures making emergency facilities available to accident victims as early as possible by letting relatives, hospital or a rescue team know the accident spot with the help of this module embedded in the vehicle. Sensors are attached to the microcontroller. In case there is an accident, the sensor gets activated and the GSM system will send notifications to the nearest hospital, police station or kind of the victim with the location coordinates where the accident has occurred. With the help of space navigation system GPS locates the position of the vehicle where accident has occurred.

Index Terms—GPS modem, Arduino, shock sensor.

I. INTRODUCTION

Traffic is on the rise as the demand for vehicles is getting higher day by day. So, transportation needs improvement as, since demands are increasing, there will be more possibility of vehicle accidents. Vehicle accidents are one of the leading causes of the fatalities. It will be a serious consequence if people can't get help on right time. Poor emergency incident is a major cause of death rate in our country. Crash analysis studies have shown, traffic accidents could have been prevented with the use of this advanced life saving measure.

This design focuses on providing basic information on the accident site to the hospital or police station. As a result of this sudden help, precious life may get saved. In this work, a three-axis accelerometer and GPS tracking system work for accidental monitoring. This design detects accidents in less time and sends this information to the required authorities.

In this case GSM will send short message to the hospital or police station. This message will read the geographical co-ordinates of accident spot with the help of GPS. And, as now the location has been traced by the GPS, emergency medical service can be given to the accident victims as soon as possible.

A key will be provided for the driver. If the accident is very normal, or driver has hit the wall in some situations like

parking then driver will press the key. This will inform the microcontroller that this is a very normal accident. But if driver is not in situation to press the switch or if the accident is really a major accident then driver will not press the key. Then microcontroller will get the coordinates from the GPS modem then it will send this information to the GSM modem, GSM modem is used to send this information via SMS. SMS will be sent to the family member of the driver, so that they can take immediate action to help the persons suffering due to this accident.

II. SYSTEM DESIGN

A 9V portable power supply will power the Arduino board. The GPS + GSM shield and the impact sensor will derive power from the Arduino board itself. The circuit is first initialized and the GPS + GSM module is turned on. The system waits till the GSM module acquires a signal and is registered with the network. The system then goes on standby until the impact sensor gives a positive output. Once the accident is detected, Arduino acquires the current location of the vehicle using the GPS module and the co-ordinates are then sent via SMS to emergency services and/or contacts the user may have stored.

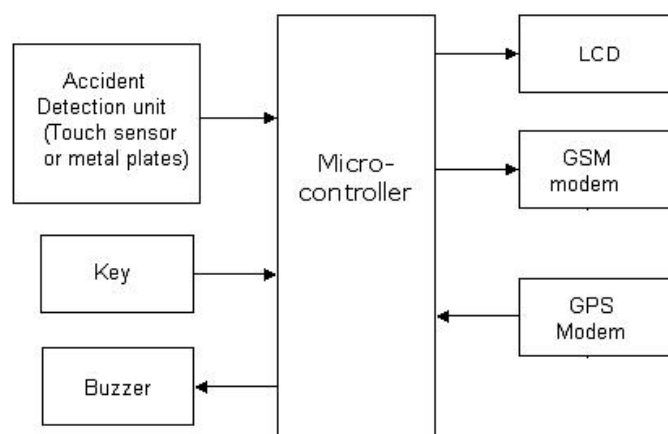

Fig. 1. Block diagram

The major components used in this device are: 1) Arduino Uno Atmel328P 2) GPS EB-3531 with external antenna 3) GSM Module with SIM Card 300 4) Shock Sensor

III. SYSTEM IMPLEMENTATION

Arduino: Arduino is an open-source computer hardware and software company, project and user community that designs and manufactures microcontroller-based kits for building digital devices and interactive objects that can sense and control the physical world. The project is based on a family of microcontroller board designs manufactured primarily by SmartProjects in Italy, and also by several other vendors, using various 8-bit Atmel AVR microcontrollers or 32-bit Atmel ARM processors. These systems provide sets of digital and analog I/O pins that can be interfaced to various expansion boards. The boards feature serial communications interfaces, including USB on some models, for loading programs from personal computers. For programming the microcontrollers, the Arduino platform provides an integrated development environment (IDE) based on the Processing project, which includes support for C, C++ and Java programming languages.

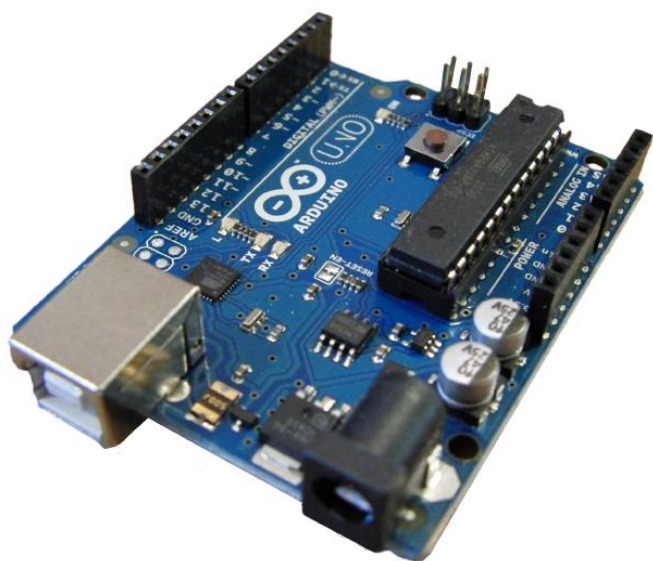

Fig. 2. Arduino Uno

GPS and GSM Module: GPS abbreviates global positioning system and this is used to detect the latitude and longitude of the particular position and it also shows the exact time. It detects these values anywhere on the earth. In our project it plays main role and it is the main source of the latitude and longitude of the vehicle to know the accident occurred location, or even for theft tracking of the vehicle. This gadget gets the coordinates from the satellite for each and every

second. This device is the main component of vehicle tracking project.

The Global Positioning System (GPS) is a satellite based navigation system that sends and receives radio signals. A GPS receiver acquires these signals and provides the user with information. Using GPS technology, one can determine location, velocity and time, 24 hours a day, in any weather conditions anywhere in the world for free. The main application of this system is track the vehicle using the GPS receiver. This receiver gives the information about its position whenever required in the form of latitudes and longitudes. This is done with the help of the GPS satellite and the GPS module attached to the vehicle which needs to be tracked.

GSM is an open, digital cellular technology used for transmitting mobile voice and data services. We can track the vehicle continuously and also inform to the Local ambulance if the vehicle is met with any accident using GSM technology. This is an inexpensive device which reduces the problem associated with accident notification and antitheft control. If the user is somewhere far from the vehicle and he wants to know where his vehicle is right from the place he is standing, he has to send a predefined message to the modem. The controlling unit will be fixed to the vehicle. The controlling unit contains the microcontroller and the GSM modem interfaced to it. The microcontroller continuously checks whether it has received any message from the modem. Finally it receives the message and transmits the information to owner of the vehicle. This a second generation (2G) mobile network. This is widely used in all over the world for mobile communication. This GSM device consists of sim slot in which a sim card can be inserted which has a unique number, this unique number is used for contact. This GSM device consists of a unique number called IMEI number and this is different for each and every hardware kit. In our project the device is used for transmitting data. The data from GPS is transmitted to given mobile through this GSM itself[3].



Fig. 3. SIM300 and EB-3531 with external antenna

Shock Sensor: The sensor used to detect accident is shock sensor. This is a single stage shock sensor, it detects any hard impact acted on it. The output from sensor after impact will be +5v and connected to INT (pin 12) of processor. These sensors are fixed on all sides of the car to detect impact occurred on it. These outputs from sensors is send into OR gate to detect at least one impact. It is integrated in the circuit system by connecting all the sensors to or gate whose output is connected to the int pin of microcontroller. These sensors are

connected in such a way that they detect force impact occurring from any side of the car. This is concerned to the safety of the system of the human driving the car so that once accident is detected the paramedics can reach to the location as soon as they can.

IV. SOFTWARE IMPLEMENTATION

The main aim of the system is to develop a low cost solution for tracking vehicular accidents. The proposed system works in two phases. In the first phase, the Arduino monitors the pin at which the impact sensor is connected and waits for the input to get active. In the second phase, the GPS receiver fetches the GPS location, after calculating the exact location, the GSM module creates a SMS which includes the location of the accident and sends it to respective authorities.

Arduino IDE:

The Arduino integrated development environment (IDE) is a cross-platform application written in Java, and derives from the IDE for the Processing programming language and the Wiring projects. It is designed to introduce programming to artists and other newcomers unfamiliar with software development. It includes a code editor with features such as syntax highlighting, brace matching, and automatic indentation, and is also capable of compiling and uploading programs to the board with a single click. A program or code written for Arduino is called a "sketch".

Arduino programs are written in C or C++. The Arduino IDE comes with a software library called "Wiring" from the original Wiring project, which makes many common input/output operations much easier.

The users need only to define two functions to make an executable cyclic executive program: 1) setup(): a function that runs once at the start of a program and that can initialize settings. 2) loop(): a function called repeatedly until the board powers off.

Flowchart for accident tracking:

1. Start
2. Power on all the modules
3. Wait for the shock sensor to detect accident
4. Get the current location from the GPS modem
5. Check whether the GSM modem is registered on the network
6. Send the SMS

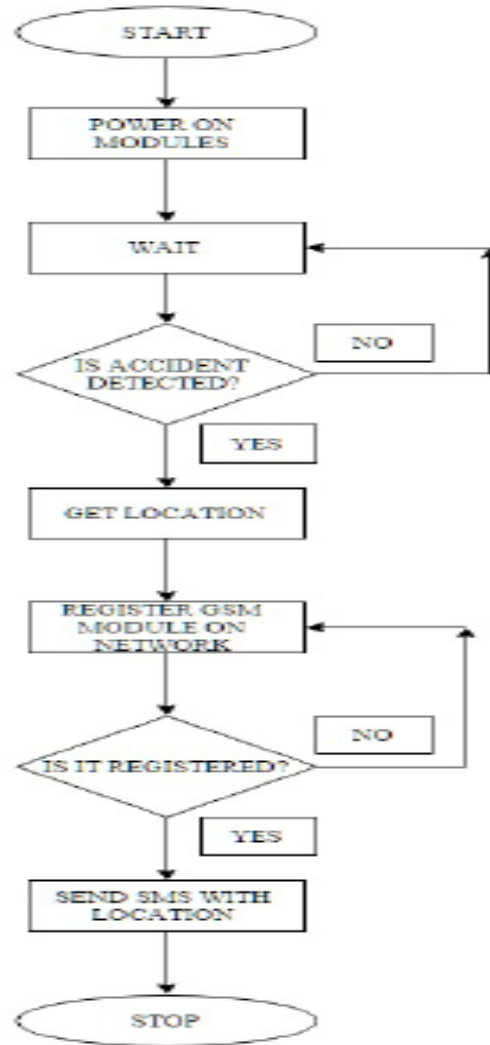

Fig. 4 Algorithm of software

V. RESULTS

Whenever accident of the vehicle occurs, then the device sends a message with the information of accident location and the time to the predefined numbers so that help can be made available. The message sent with the help of the GSM module will appear like this - Message for accident: Accident occurred. Please send help." This system shows the location of vehicle where the accident has occurred with the help of the GPS module connected to it and hence that information is added in the accident alerting message.

VI. CONCLUSION

This project provides the design which has the advantages of low cost, portability and small size. The platform of the system is AVR along with accelerometer sensor; GPS and GSM, interfacing which reduces the alarm time to a large extent and locates the site of accident accurately. This system can overcome the problems of lack of automated system for accident location detection. Consequently, the time for searching the location is reduced and the person can be treated as soon as possible which will save many lives.

Main motto of the accident alert system project is to decrease the chances of casualties in such accident. Whenever accident occurs, paramedics are alerted and they reach the particular location to increase the chances of saving life. This device invention is much more useful for the accidents occurred in deserted places and those occurring at night time which usually go unattended. This system will have broad application prospects and it will play an important role in day to day life in future.

REFERENCES

- [1] Theodore S. Rappaport, Wireless Communications, Prentice Hall of India, 2nd Edition, 2002.
- [2] Vikas Desai, Design and Implementation of GSM and GPS Based Vehicle Accident Detection System, IJIT, Vol 01, Issue 03 2013.
- [3] M.AL-Rousan, A. R. AI-Ali and K. Darwish, GSM-Based Mobile Tele Monitoring and Management System for Inter-Cities Public Transportations, ICIT,2004.
- [4] R.SGaonkar, Microprocessor architecture programming and Application Wiley Eastern Ltd., New Delhi.
- [5] P. D. Patinge, N. R. Kolhare (July 2012), Smart Onboard Public Information System using GPS and GSM Integration for Public Transport, International Journal of Advanced Research in Computer and Communication Engineering, Vol. 1, Issue V.
- [6] William Stallng, Wireless Communication and Networks, 2nd edition, 2005 Prentice Hall of India.