

SOLAR POWER BOOSTER WITH UNIFIED POWER FACTOR

¹GOLE VRUSHALI, ²MAHAJAN NIKITA, ³MORE PRIYANKA, ⁴TARTE PRATIMA, ⁵SUTAR ANAND,

^{1,2,3,4}Bachelor of Engineering, Department of Electronics and Telecommunication Engineering, Bharati Vidyapeeth College of Engineering, Navi Mumbai.

⁵ Assistant Professor, Department of Electronics and Communication Engineering, Bharati Vidyapeeth college of Engineering, Navi Mumbai

¹golevrushali@gmail.com, ² mahajannikita@gmail.com, ³ march24morepriyanka@gmail.com, ⁴ tartepratima@gmail.com, ⁵avsutar@gmail.com

Abstract—In this paper we report a project by which we are not only use a Renewable Energy Source i.e. solar energy but also maintain power factor at unity. Automatic power factor correction techniques can be applied to the industries, power systems and also house-holds to make them stable and due to that the system becomes stable and efficiency of the system as well as the apparatus increases. The use of microcontroller reduces the costs. In this project, the power factor of the electricity become unity and there will not be any reflection of received power, by this project we will pay only for that electricity which we are actually using in reality. Also we can store the energy in battery so that we can use the power anytime i.e. during night and rainy season also. By this project we become independent of MSEB.

Index Terms— Power Factor, Beer Analogy, Active Power, Reactive Power, Solar panel, DC battery, Inverter, Transformer, Load, etc.

I. INTRODUCTION

The basic block diagram of this project is shown in fig. 1.

A. Block Diagram

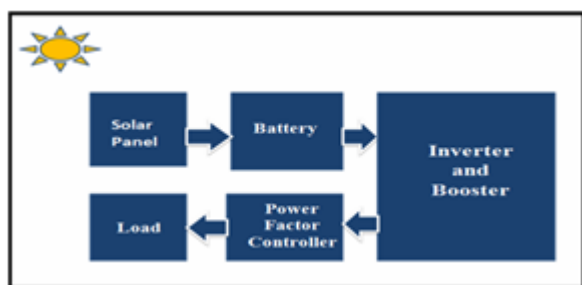

Fig.1: Basic Block Diagram of Project

1. Solar panel
2. Battery
3. Inverter and booster
4. Power factor controller
5. Load

1) Solar Pane



Fig. 2 Solar Panel

Solar Panel	20W	50W	100W
Solar Part Number	SOL-MS20	SOL-MS50	SOL-MS100
Storage battery	12V/17AH maintenance free acid-lead battery	12V/40AH maintenance free acid-lead battery	12V/85AH maintenance free acid-lead battery
Controller	12V/10A	12V/10A	12V/20A
Inverter	200W 220V 0.9A	300W 220V 1.5A	300W 220V 1.5A
Rated power	150W	300W	300W
Peak power	200W	350W	350W
Rated output	100W	200W	200W
Charging time	10hrs	10hrs	10hrs
Battery voltage	12V	12V	12V
Output frequency	50HZ	50HZ	50HZ
Output voltage	5V, 12V, 16V	5V, 12V, 16V	5V, 16V
Conversion efficiency	85%	85%	85%
Power factor	0.8	0.8	0.8
Working temperature	-20°C-50°C	-20°C-50°C	-20°C-50°C
Unit size	46.5x31x25cm	72x37x34cm	73x39x52cm
Net weight	15KG	30KG	54KG
Price	\$676.40	\$1,292.00	\$2,452.90

Table no.1

Solar panel is a device which absorb the sun's rays as a source of energy in order to generate electricity. It's a photovoltaic modules use light energy (photons) from the sun to generate electricity through the photovoltaic effect. This power can be store in battery

2) Battery



Fig.3: Battery

It is a device consisting of one or more electrochemical cells. It is used to store dc power that is generated by solar cell.

3. Inverter and booster [2][3]:

Inverters are often needed at places where it is not possible to get AC supply from the Mains. An inverter circuit is used to convert the DC power to AC power. Inverters can be of two types True/pure sine wave inverters and quasi or modified inverters. These true /pure sine wave inverters are costly, while modified or quasi inverters are inexpensive.

These modified inverters produce a square wave and these are not used to power delicate electronic equipments. Here, a simple voltage driven inverter circuit using power transistors as switching devices is build, which converts 12V DC signal to single phase 220V AC. The basic idea behind every inverter circuit is to produce oscillations using the given DC and apply these oscillations across the primary of the transformer by amplifying the current. This primary voltage is then stepped up to a higher voltage depending upon the number of turns in primary and secondary coils. A 12V DC to 220 V AC converter can also be designed using simple transistors. It can be used to power lamps up to 35W but can be made to drive more powerful loads by adding more MOSFETS.

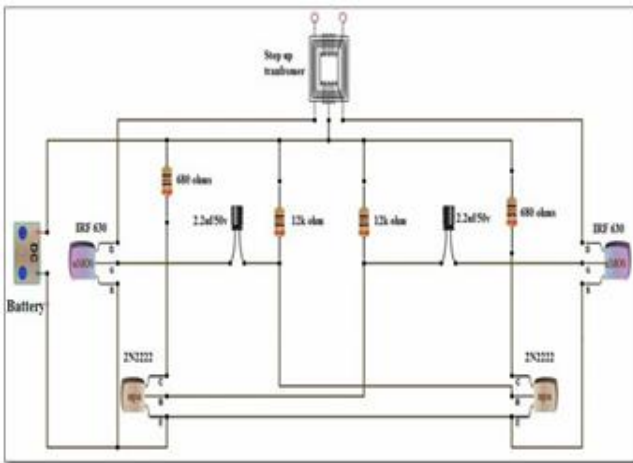

Fig.4: Inverter and Booster Circuit

4. Power Factor Controller[4]:

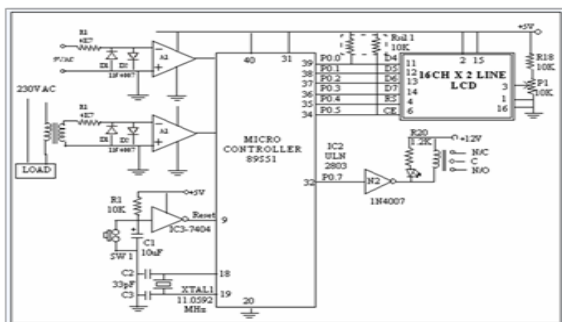

Fig.5 [1]: Unified Power Factor Controller Circuit

Power factor is defined as the ratio of real power to apparent power. This definition is often mathematically

represented as KW/KVA, where the numerator is the active (real) power and the denominator is the (active + reactive) or apparent power. Reactive power is the non working power generated by the magnetic and inductive loads, to generate magnetic flux.

The increase in reactive power increases the apparent power, so the power factor decreases and efficiency also decreases.

Mug Capacity = Apparent Power (KVA) Foam = Reactive Power (KVAR)

Beer = Real Power (kW)

Power Factor = Beer (kW) / Mug Capacity (KVA)

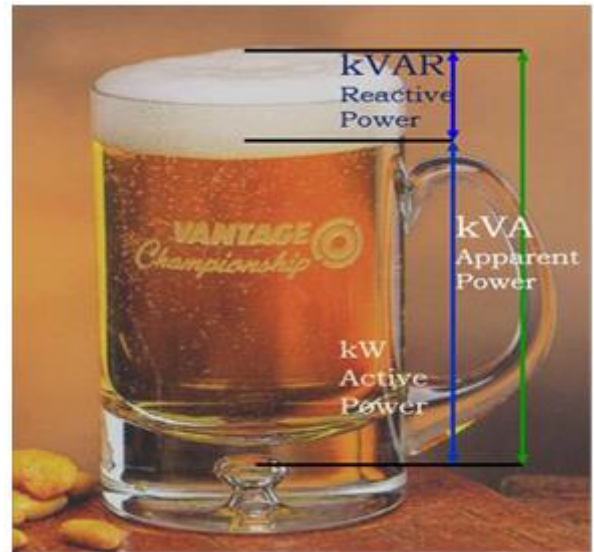

Fig.6: Beer analogy

II. PURPOSE OF RESEARCH:

Increased electricity costs by paying power factor surcharges. Lack of energy resources: In today's situation, the population of world is growing at very high rate, in order to fulfill the requirement of energy we have to generate a lot of electricity which is not an easy task. Also there is less resources are available on earth, by this project we use .The of the clean and pollution free source.

III. WORKING

In this proposed system, the time lag between the voltage pulse and current pulse duty generated by suitable operational amplifier circuits in comparator mode are fed to two interrupt pins of the microcontroller. The microcontroller used is of 89s51 family. It displays the time lag between the current and voltage on an LCD (16 Character x 2 Line). The program takes over a relay driver (ULN2803) at its output for bringing shunt capacitors into the load circuit to get the power factor till it reaches unity.

IV. ADVANTAGES:

- 1) Use renewable energy source (solar energy)

- 2) Independent on MSEB electricity supply
- 3) Save money.
- 4) Most reliable solar panel manufacturers give 20-25 years warranty.
- 5) Eliminate power factor penalties
- 6) Increase system capacity.

V. APPLICATIONS:

This model is applicable for domestic purpose as well as small-scale industries.:

VI. ON-GOING PROJECT:

Recently, the technical revolution made embedded technology cheaper, so that it can be applied to all the fields. The pioneer manufactures of Power system and protection system such as SIMENS, LARSON & TUBRO, and CUTLER HAMPER etc. manufacturing power factor improvement devices on embedded technology.

VII. FUTURE ENHANCEMENT

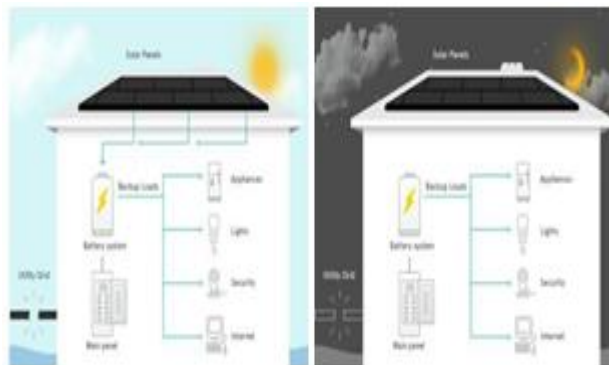

FIG.7: FUTURE SCOPE

So, considering all these facts, the combination of electricity demand growth, fossil fuel cost and availability challenges, and supportive environmental regulations could increase solar power capacity to more than 50 GW by 2022.

REFERENCES

- [1] "The 8051 Microcontroller and Embedded Systems" by Muhammad Ali Mazidi and Janice Gillispie Mazidi.
- [2] PWM for Power Electronics converter lecture by G. Narayanan
- [3] G. Narayanan
- [4] M. Machmoum, P. Coulibaly and P. Abdelli, "A power factor controller for three-phase pwm rectifiers and shunt active power filters," Proceedings of IEEE Conference on Harmonics and Quality of Power, vol. 2, pp. 626-631, 2002.
- [5] Power Electronics by M. Singh and khanchandani, 2nd Edition, Tata McGraw-Hill Education.