

REVIEW ON INTELLIGENT LOCKER SYSTEM BASED ON CRYPTOGRAPHY, WIRELESS&EMBEDED TECHNOLOGY

¹Rajan Jagdale, ² SankalpKoli, ³ SaurabhKadam, ⁴SiddeshGurav ,
BE EXTC

Department of Electronics and Telecommunication Engineering,
K.C. College of Engineering & Management studies & Research,
Kopri,Thane(E)-400 603, India.

¹rajan.rajan.jagdale@gmail.com, ²sankkoli@gmail.com, ³rocker.saurabh94@gmail.com, ⁴sidgurav5@gmail.com

Abstract— Security is a prime concern in our day-today life. Everyone wants to be as much secure as possible. An access control for doors forms a vital link in a [security](#) chain. The microcontroller based digital lock for Doors is an access control system that allows only authorized persons to access a restricted area. The system is fully controlled by the 8 bit microcontroller AT89S52 which has a 8Kbytes of ROM for the program memory. The password is stored in the EPROM so that we can change it at any time. The system has a Keypad by which the password can be entered through it. When they entered password equals with the password stored in the memory then the motor gets activated so that the door is opened. If we entered a wrong password a buzzer is switched on and error is indicated. The user is required to enter the code again after some delay.

Index terms- cryptography encryption& decryption, Microcontroller, EmbeddedSystem, Secure Access.

I. INTRODUCTION

Here we are introducing a technology based on Embedded and wireless. This Project provide Globally Security to the human being .Means we can implement this project globally anywhere. We want such as Home, office industry etc. The microcontroller & cryptography based digital locker is an access control system that allows only authorized persons to access a restricted area The system is fully controlled by the 8 bit microcontroller.ATMEL 89S52 has 8K bytes of in-system programmable EPROM memory.The password is stored in the memory so that we can change it at any time.[5] The system has a Keypad by which the password can be entered through it. When we enter password and it is match with the password stored in the memory then the motor gets activated so that the door of locker is opened. If we entered a wrong password a buzzer is switched on and error is indicated. The user is required to enter the code again after some delay. The system comprises a small electronic unit with a numeric keypad, which is fixed outside the entry door to control a solenoid-operated lock with the help of a stepper motor. When an authorized person enters predetermined user ID and password via the keypad, the stepper motor is operated for a limited time to unlatch the solenoid-operated lock so the door can be open.

At the end of preset delay, the stepper motor is operated in reverse direction and the door gets locked again. When the code has been incorrectly entered three times in a row, the code lock will switch to block mode. This function thwarts any attempt by ‘hackers’ to quickly try a large number of codes in a sequence. If the user forgets his password, the code lock can be accessed by a unique 10 digit administrator password. The secret code can be changed any time after entering the current code (Master code)[2].

II. OTHER DOOR LOCK SYSTEMS AVAILABLE

There are lots of security systems in the market nowadays. These systems are studied in order to obtain some idea for the project that was built. Although the system in the market nowadays is suite with new technology and more advanced the idea must still need to be obtain through the literature review. The literature review works help to exposé and generate skills of searching for information from a various sources. These skills are very important in order to solve the problems that encountered or will face in the future. The Basic requirement of security can be achieved by designing electrical or mechanical locks that are designed with one or a few keys, but for locking a big area many locks are required. Basically traditional locks are heavy and are not protective as they can be broken down easily by using some tools. Electronic locking systems are preferable over mechanical locks, to resolve the security problems that are associated with the mechanical locks [1].Nowadays every device’s operation is based on digital technology. For instance, token-based digital identity devices, Fort-token mobile and digital-based door lock systems for auto are all based on digital technology. These locking systems are used to control the movement of door and are functional without requiring a key to lock or unlock the door. These locking systems are controlled by a keypad and are installed at the side hedge of the door.There are lots of security systems in the market nowadays. These systems are studied in order to obtain some idea for the project that was built. Although the system in the market nowadays is suite with new technology and more advanced the idea must still need to be obtain

through the literature review. The literature review works help to expose and generate skills of searching for information from a various sources. These skills are very important in order to solve the problems that are encountered so far or will be faced in the future. Following is the block diagram of the Proposed Work

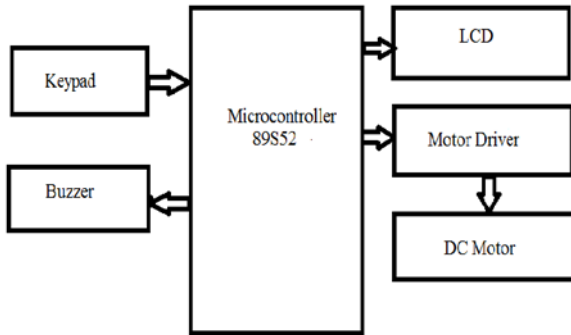

Fig1: Block Diagram

III. BLOCK DIAGRAM DESCRIPTION

Password based door lock circuit design uses four major components – a Microcontroller, a DC motor, 16*2a matrix keypad and a LCD. Here AT89S52 microcontroller is used and it is an 8-bit controller. This controller requires a supply voltage of +5V DC. [1] In order to provide regulated 5V DC voltage to the controller we need to use 7805 power supply circuit. We can use 9V DC battery or 12V, 1A adaptor as a power source. Once the circuit is powered, microcontroller sends commands to the LCD to display “enter password” on LCD. Now we need to enter the password using the keypad. Once password is entered, it displays 5 stars on LCD to indicate that controller read password successfully. Now the controller compares the entered password with predefined password. If the password is matched then controller makes P3.0 high. So the base of the transistor gets sufficient current to drive the relay, as a result Door motor rotates to open the door. If the password is not matched then microcontroller makes P3.0 low. Hence door motor is at stationary so that door remains close[4].

IV. PASSWORD BASED DOOR LOCK SYSTEM ALGORITHM:

- Initially declare the PORT1 to LCD data pins and control pins to P3.5, P3.6 and P3.7 and declare PORT2 to keypad. And use P3.0 to Door motor.
- Initially display enter password on LCD.
- Now read the five digit password from the user, while reading each digit from the keypad display * symbol on LCD.
- Compare the entered password with stored password.

- If password is correct then make P3.0 pin high for some time to open the door. After that display “Door is opened” on LCD.
- If the password is wrong then display “pwd is wrong” on LCD.
- After some delay again ask to enter password.[1]

V. CRYPTOGRAPHY ENCRYPTION/ DECRYPTION

Cryptography is method of storing and transmitting data in a particular form so that only those for whom it is intended can read & process it. The term is most often associated with scrambling plaintext (ordinary text, sometime referred to as clear text) into ciphertext (a process is called as encryption), then back again (known as decryption)[3]. In this project, we are using cryptography software. Consider 4 employees are working under a Boss, while accessing a bank, a common password is given to all 4 employees. If the 1st employee enter a password then if it is correct then due to the use of GSM module it will inform the boss and after this the boss will give new password to the 1st employee from which he can access the lock. Here the cryptography software will be use while entering the common password. Consider the microcontroller chip entered in the lock will have common password of 1111. The employer will insert a common password 1111. Then it will try to match with the set password in microcontroller, if it is match then only the lock will be open, but in this case there may be possibility of hacking the password, when an corrupted employer comes, he may read the microcontroller chip, the microcontroller reader can hack the password, by using cryptography it can avoided. Now consider the password set in microcontroller chip is 0000. While encrypting, the employer will encrypt 1111. Here the cryptography software works. The software change the set password 0000 of microcontroller to 1111. That is it will decrypt it, therefore entered password will match and lock will be open. If the hacker try to hack the chip, he will read set password 0000, and while entering he may enter 0000 which may be wrong and lock SMS will may not sent to the boss.[2]

An electronic lock is a device which has an electronic control assembly attached to it. They are provided with an access control system. This system allows the user to unlock the device with a password. The password is entered by making use of a keypad. The user can also set his password to ensure better protection. The major components include a keypad, LCD and the controller AT89C52 which belongs to the 8051 series of microcontrollers. Data transmitted over the Internet passes through many servers and/or routers and there are many opportunities for third parties to intercept that transmission. Preventing interception is impossible; instead, the data must be made unreadable (encrypted) during transmission, with away for the intended

recipient to be able to transform the received transmission back to its readable form (unencrypted). Bitwise automatically encrypts all data exchanged (including file transfers) between Bitwise users to ensure confidentiality. Encryption is the manipulation of data, based on a password (also known as a key), for security purposes. Once your data has been encrypted, a person cannot make sense of your data without knowing the password (or figuring it out). For example, if we take HAL and add 1 to each of the letters, we get IBM. In this case, the password is simply "1". If we use "123456" as our password, then we add 1 to the first letter, 2 to the second, 6 to the sixth, then we start over at 1 and add 1 to the seventh letter. Now our encrypted data is, "ICN". To decrypt, the password "123456" is "subtracted" from our data. Sophisticated software can make intelligent guesses of the password to decrypt data. One easy way is with a database of common passwords. A more difficult way is by analyzing the encrypted data. If you know the decrypted data starts with 20 spaces, and then you subtract 20 spaces from the data, you will get "12345612345612345612" if the Password was "123456". A longer password makes it more difficult to decrypt the data without knowing the password. Another way security could be breached is if someone were to tap into a transmission. The Internet is a worldwide network of computers. If you were to send unencrypted data across the Internet, someone may be able to view the data if they operate a part of the Internet your data must pass through. This is why you should not send credit card information over the Internet unless you use "Secure mode". Each web browser has its own way of letting you know that it is in secure mode. Check the help system of your web browser for more information [2][6].

VI. ADVANTAGES

- We can Accesses 100 % security
- Access control for doors forms a vital link in a security chain
- Digital lock for Doors is an access control system that allows only authorized persons to access a restricted area.
- Portable

VII. APPLICATION

- In Bank
- At Home
- In Hospital
- In Jewelries Showroom

- In Mall

VIII. CONCLUSION

Password based door lock system using cryptography and embedded technology is used where we need more security. This is fully protective system and we can protect our assurances. Cryptography is used to manipulate the data so that no one can understand the original password. We can change the password at any time. Cross verification is done to verify that only authorized person access the system. The system comprises a number keypad and the keypads are connected to the 8 bit microcontroller AT89S52. The microcontroller continuously monitor the keypad and if somebody entered the password it will check with the password which was stored in the memory and if they are same the microcontroller will switch on the corresponding device. The will allow the person who knows the password and it will not allow who don't know the password.

IX. FUTURE DEVELOPMENT

- We can send the data to a remote location using mobile and internet.
- We can implement other modules like fire and wind sensor so that in case of accident door will be automatically open.
- We can add Fingerprint sensor so entry will allow for authorized person.

REFERENCES

1. <http://www.electronics.engineeringminiprojects.com/password-based-door-locking-system/>
2. Liddell, Henry George; scot, Robert; Jones, Henry Stuart; Mackenzie, Roderick (1984) Rivest, Ronald L. (1990). "Cryptography". In, J. van Leeuwen, Handbook of theoretical computer science
3. GOOGLE search on cryptography.
4. 8051 MICROCONTROLLER AN EMBEDDED SYSTEM BY MOHAMMED ALI MAZIDI, PUBLISHER-PRENTICE Hall of INDIA Ltd.
5. "8051 MICROCONTROLLER" BY K. J. AYALA. Publisher
6. WHITFIELD DIFFIE AND MARTIN E. HELLMAN, "New direction in Cryptography" submitted to IEEE Transactions on information theory, vol IT-22, NO. 6, November 1976.