

# OPEN LOOP ANALYSIS OF CASCADED H-BRIDGE MULTILEVEL INVERTER USING PD-PWM FOR PHOTOVOLTAIC SYSTEMS

Sangeetha R Gupta, Dr.Anitha G.S

Dept. of Electrical and Electronics Engg.  
RV College of Engineering, Bengaluru, India  
sangeetharamgupta@gmail.com

**Abstract-**This project aims at using (PD-MCPWM) Phase disposition multi carrier pulse width modulation technique to reduce leakage current in a transformerless cascaded multilevel inverter for PV systems. Advantages of transformerless PV inverter topology is as follows, simple structure, low weight and provides higher efficiency, but however this topology provides a path for the leakage current to flow through the parasitic capacitance formed between the PV module and the ground. Modulation technique reduces leakage current with an added advantage without adding any extra components.

## I. INTRODUCTION

The photovoltaic systems relatively generate less power when compared to other common energy resources, due to its high installation cost. In the recent research reducing PV system cost and increasing its efficiency is of greatest interest.

By removing the transformer that is required at the output of the PV inverter the cost of the PV power systems can be reduced [1]-[2]. Usage of transformers above certain threshold power in the system in order to provide galvanic isolation was made compulsory by most of the national electricity regulatory authority. But usage of transformers has its own disadvantages like it increases the weight, size and cost of PV system and also reduces the power conversion efficiency.

The above advantages in removal of transformer has motivated the research community to work in the transformerless PV system. However removal of transformer in the output of the PV inverter introduces harmful leakage current to flow through the parasitic capacitance that exist between PV module and ground. The induced leakage current, electromagnetic interferences and safety concerns [4]-[5].

Two and three level inverters are unable to provide higher efficiency and grid code requirements for higher power and voltage ratings. Therefore medium and megawatt scale PV inverters are moving towards the multilevel structures

## II. MULTILEVEL INVERTERS AND THEIR TOPOLOGIES

Multilevel inverters which is also like inverters was introduced during 1970's for industrial applications as alternative in high power and medium voltage situations. The requirement of multilevel inverters is to give high output power from medium voltage sources like solar panels, batteries, super capacitors etc.

Even though the industrial applications have started using high power for their applications, some of the appliances in industries still requires medium and low power for their operations.

## TYPES OF MULTILEVEL INVERTERS

Multilevel inverters are usually of three types:

- Diode clamped multilevel inverter.
  - Flying Capacitors multilevel inverter.
  - Cascaded H-bridge multilevel inverter.
- A. *Diode clamped multilevel inverter:*

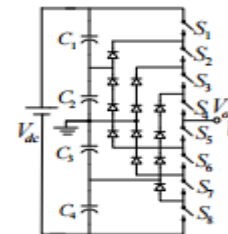
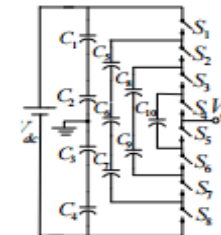

**Fig 1: Diode clamped multilevel inverter**

This type of multilevel inverter uses diodes and provides multiple voltage levels through phases of capacitor banks that are in series. But the main disadvantage of this type is that the output voltage will be half of the input DC voltage.

In order to increase the output voltage the number of switches, diodes and capacitors has to be increased. Due to voltage balancing issues they are limited to three levels.

- B. *Flying capacitors multilevel inverters*



**Fig 2: Flying capacitors multilevel inverters**

They are similar to diode clamped multilevel inverters except that it uses series connection of capacitor clamped switching cells and also that it does not require diodes. But the main disadvantage of this system is that the output voltage is half of the input DC voltage.

- C. *Cascaded H-bridge multilevel inverter*

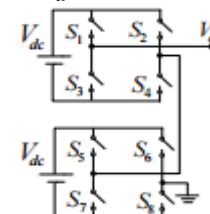

**Fig 3: Cascaded H-bridge multilevel inverter**

The disadvantages of the above two types is overcome by cascaded H-bridge multilevel inverter, it uses capacitors, switches and requires very less number of components in each level, thus reducing in price and weight than the other two above.

### III. DIFFERENT MC-PWM FOR MI

The commonly used modulation to provide constant CMV is SVM and MCPWM. But in SVM even though the user select the switching sequence and modulation, it requires large number of computations.

And also selecting the switching states is very difficult for implementations on practical basis. The above problems can be overcome by MC-PWM.

There are different classification of multi carrier pulse width modulations like Level shifted pulse width modulation,

Phase disposition pulse width modulation and Phase opposite disposition pulse width modulation etc

#### A. Phase disposition pulse width modulation:

Phase disposition PWM has carrier in same phase above and below zero reference line. All the carriers are in same phase in this method of PWM. Most widely used method as it provides load voltage and current with lower harmonic distortion.

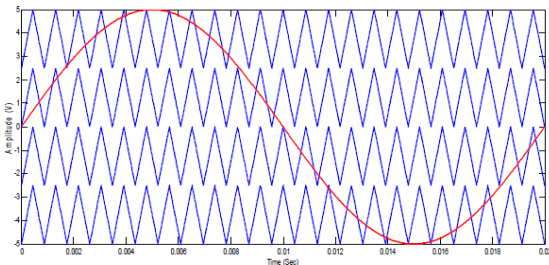

Fig 4:Phase disposition PWM carrier arrangement

#### B. Phase opposite disposition pulse width modulation:

Unlike the phase disposition this method has all carriers at the same frequency with adjustable amplitudes. The only difference that it has when compared to the above method is that it has carriers above zero level reference in phase among them but in opposition usually 180 degrees phase shifted with those of below.

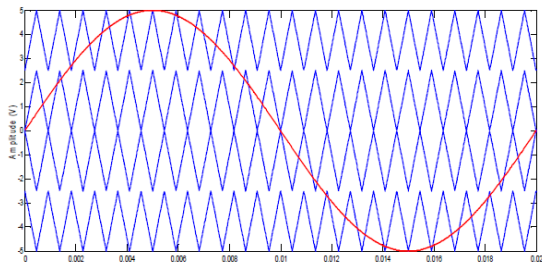

Fig 5: Phase opposite disposition PWM carrier arrangement

### IV. PROPOSED SYSTEM

The cascaded H-bridge has the advantage of reducing leakage current when it is compared to other two types of bridge topology because it has reduced value of DC link voltage per bridge. Also on the load side the grid is shown as a

simple resistor load for simplicity in simulation, as it has no role to play in affecting the leakage current. The MC-PWM that has to be applied to the above proposed system is PD-PWM has it has proven to be providing more encouraging results.

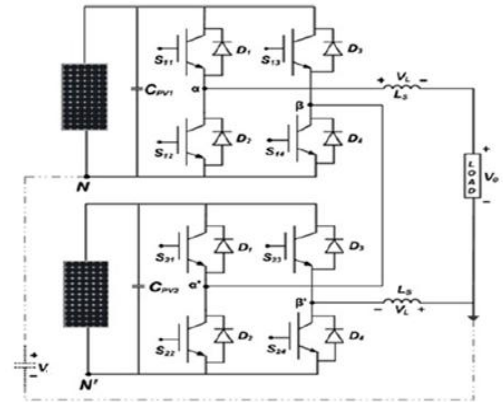

Fig 6: Proposed Single –phase five-level cascaded multilevel inverter

### V. OPEN LOOP SIMULATION

Using MATLAB simulation tool, open circuit is modeled in Simulink in Figure 7, and is simulated with PD-PWM technique. The parameters used in the simulation can be tabulated as given below in table 1.

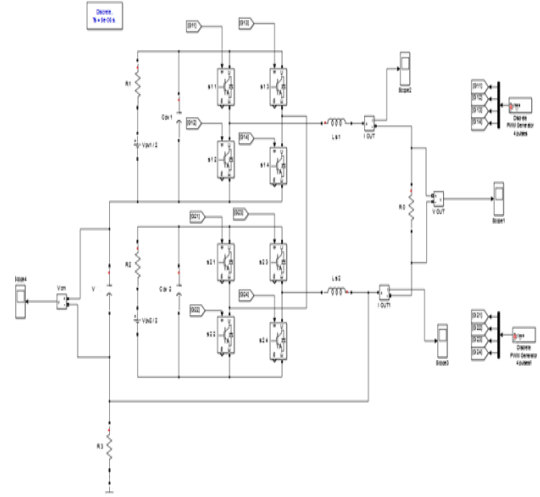
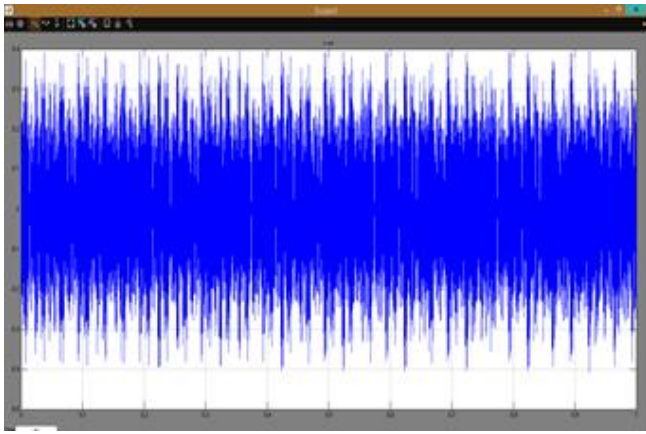

Fig 7: Open loop Simulink model

Table 1. Parameters used in the simulation

Sl no	Parameters	Values considered for simulation
1	PV module	50W
2	DC-link capacitance	2200uF
3	Switching frequency	3KHz
4	Inductance	5Mh
5	Input voltage	20 V
6	Output voltage	40V
7	Load resistance	10Ω



**Fig 8: Leakage current in the parasitic capacitor**

The leakage current was found to be 0.4A (refer figure 8) which has to be reduced in closed loop simulation in future work.

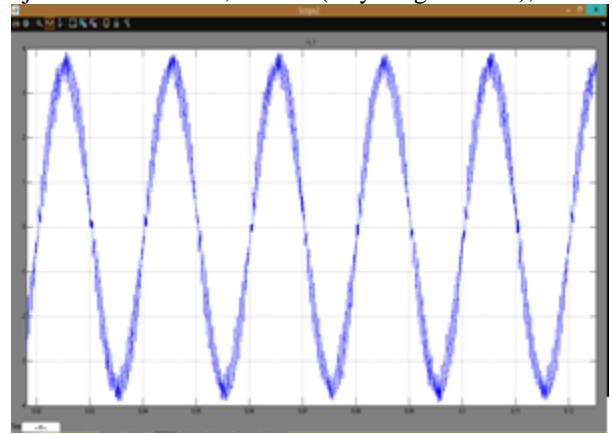

**Fig 11: Output current in the multilevel inverter**

## VI. FUTURE WORK

Using MATLAB Simulation tool, the closed loop control Simulink modeling will be obtained. The control will be simulated using PI (Proportional integrator) and also the PD-PWM modulation technique will be applied of which the results will be compared to the previous results. Using these results a code for the controller dsPIC will be developed in the hardware implementation

## REFERENCES

- [1] R. Gonzalez, J. Lopez, P. Sanchis, and L. Marroyo, "Transformerless inverter for single-phase photovoltaic systems," *IEEE Trans. Power Electron.*, vol. 22, no. 2, pp. 693–697, Mar. 2007.
- [2] Y. Wensong, L. Jih-Sheng, H. Qian, and C. Hutchens, "High-efficiency MOSFET inverter with H6-type configuration for photovoltaic nonisolated AC-module applications," *IEEE Trans. Power Electron.*, vol. 26, no. 4, pp. 1253–1260, Apr. 2011.
- [3] Y. Zhou, W. Huang, P. Zhao, and J. Zhao, "A transformerless grid connected photovoltaic system based on the coupled inductor single-stage boost three-phase inverter," *IEEE Trans. Power Electron.*, vol. 29, no. 3, pp. 1041–1046, Mar. 2014.
- [4] E. Koutroulis and F. Blaabjerg, "Design optimization of transformerless grid-connected PV inverters including reliability," *IEEE Trans. Power Electron.*, vol. 28, no. 1, pp. 325–335, Jan. 2013.
- [5] L. June-Seok and L. Kyo-Beum, "New modulation techniques for a leakage current reduction and a neutral-point voltage balance in transformerless photovoltaic systems using a three-level inverter," *IEEE Trans. Power Electron.*, vol. 29, no. 4, pp. 1720–1732, Apr. 2014.

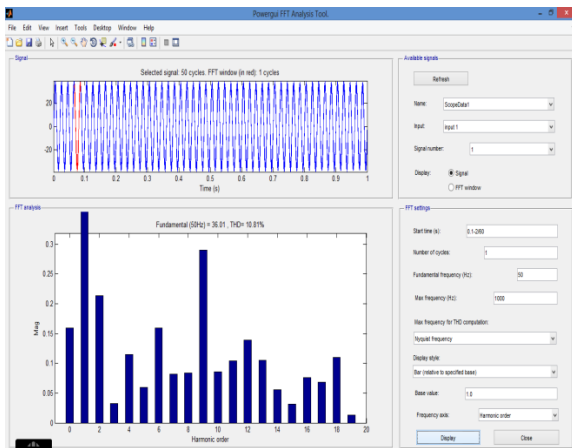

**Fig 9: THD of the proposed system**

Open simulation of the proposed system was done and it was found to be 10.81%. The desired results can be obtained by making it a closed loop system with reduction upto 4.22% (expected result) using PD-PWM.

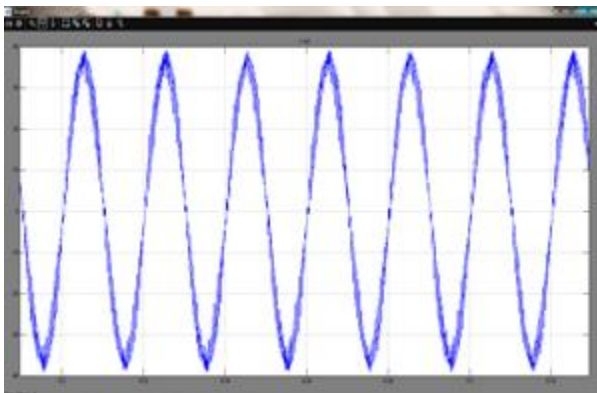

**Fig 10: Output voltage of the multilevel inverter**