

THE EFFECT OF BUILDINGS ORGANIZATION ON TRAFFIC NOISE PROPAGATION IN THE URBAN ENVIRONMENT

Dr. Hanan Al Jumaily

Associated professor, Architectural Engineering Department
Middle East University, Amman, JORDAN.

Han_jumaily@yahoo.co.uk

Abstract- This study evaluates sound performance of building's gap configuration exposed to linear finite-length sound source (e.g. traffic noise). As a mean of traffic noise attenuation to prevent sound waves penetration through these gaps to the urban area behind the buildings.

A theoretical background of the acoustical performance of buildings that act as a noise barrier between the source (vehicles) and the receiver environment is presented. These barrier buildings interrupt the straight line path from the source to the receiver, and provide a buffer zone that shields and protects sensitive areas from highway traffic noise by locating them in the noise shadow area.

Computer simulation of mathematical methods are analyzed as case studies which are applied to test the effect of different type of organization and geometrical design of exposed buildings' façades in order to examine the effect of gap depth and its shape on traffic noise penetration of direct and reflected sound waves from the sidewalls surrounding the gap and to examine their impact on noise penetration to the urban area facing traffic noise.

The objective of the research is to study the effect of buildings organization (type of grouping) and their geometrical configuration on noise penetration and geometrical spread of direct and reflected sound waves from buildings' façade around the gaps (open spaces) between these buildings to the shadow zone in aligned urban area.

I. INTRODUCTION

One of the main factors affecting urban planning and design policies for any city is noise pollution, in particular, traffic noise. Noise is considered as one of the environmental pollution factors endured by the human within his urban environment. The traffic noise problem has increased as a result of over population in cities and became a great environmental pollutant that affects human health. This is where the role of urban designers begins in studying possible methods for noise attenuation; and presenting the best solution for traffic noise penetration to the urban environment.

The Research Methodology consists of a brief theoretical background to indicate the effect of building blocks as a noise barrier on traffic noise attenuation in the urban environment.

A hypothesis is set to study the impact of the configuration and orientation of buildings' gap sidewalls on traffic noise penetration to the urban area behind these buildings.

Computer simulation of mathematical models is applied to test the validity of the given hypothesis using simulated

cases of different types of buildings gap. However, prediction methods analysis of defined variables and mathematical equations are used to estimate the resultant noise attenuation values and their relationship to the design variables.

The outcomes expected from the current study are of special interest to architects and urban designers who are mainly concerned with the configuration and orientation of buildings acting as a traffic noise barriers, and space organization between them so as to reduce the negative impacts on the urban area behind these buildings.

Results of this study indicate that the configuration of buildings' sidewalls and depth of the gap between them, affect the reflected sound level at a reception point behind the building which in turn affects traffic noise attenuation values.

Hypothesis- The geometrical configuration of buildings exposed to the linear finite-length sound source (traffic noise) influence the paths of sound wave spreading and its penetration to the urban area behind these building which affect the noise attenuation value.

II. THE IMPACT OF BARRIER BUILDINGS ON SOUND PROPAGATION IN THE URBAN ENVIRONMENT

Barrier buildings are considered as one of the methods to protect urban areas from traffic noise amongst which are forestation, topography, wall barriers (fences), etc. These solutions are significant in crowded cities as it is difficult to settle away from streets for many reasons related to planning, economics, transportation, etc.

Buildings facing main streets act as a barrier block forming a buffer zone between the noise source and the receiver environment. These buildings create a noise shadow area (Quiet Zone) behind them, where residential and noise-sensitive buildings might be located, Figure (1). The block should run along the edge of the site parallel to the noise source separating the quiet zone from traffic noise affected zone. (*Dept. of Planning, Transport and Infrastructure, 2012*).

These buildings are finite height barriers which do not block the source completely allowing for gaps in between. The gaps are considered paths for noise penetration to the area to be protected.

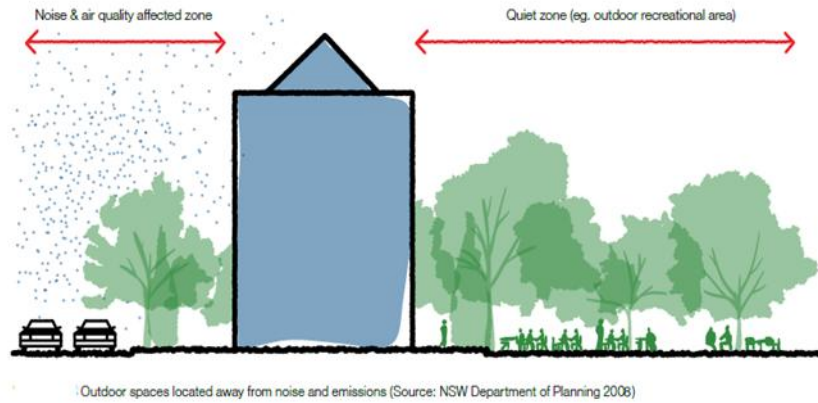

Figure (1) - Buildings act as a barrier between highway street and receiver environment

The acoustic behavior of sound waves paths which are transferred from the street to the adjacent urban environment is affected by many variables such as: (Dept. of Transport, 1988)

1. Type of Barrier buildings organization
2. Different exposure degrees of open spaces and gaps to the street
3. Different building heights
4. Buildings' orientation degree in relation with the street's direction

III. Types of Barrier Buildings Organization:

The barrier building's organization can be in the form of rows parallel to the street, or in clusters surrounding an open space.

The following factors affect the acoustical performance of buildings arranged in rows parallel to the street: (A. Lara, 1986), Figure (2).

1. The height of buildings' row (h)
2. The distance between rows (d)
3. The number of gaps between buildings that interrupt the continuity of the row allowing noise to penetrate the location.

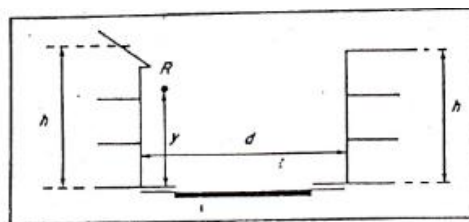

Figure (2) – the proportion between height of building's row (H) and the distance (D)

To calculate the difference between the noise level (ΔL) of two rows of buildings, the following equation is used:

$$\Delta L = 10 \log \left[1 + \frac{h}{d} \right] + 3 \quad (A. Lara, 1986)$$

The noise level in the front row of buildings is higher than the ones at the back due to the reflection of sound waves from the front façade of the buildings close to the street, Figure (3). (Ervin H. Zube, 1990).

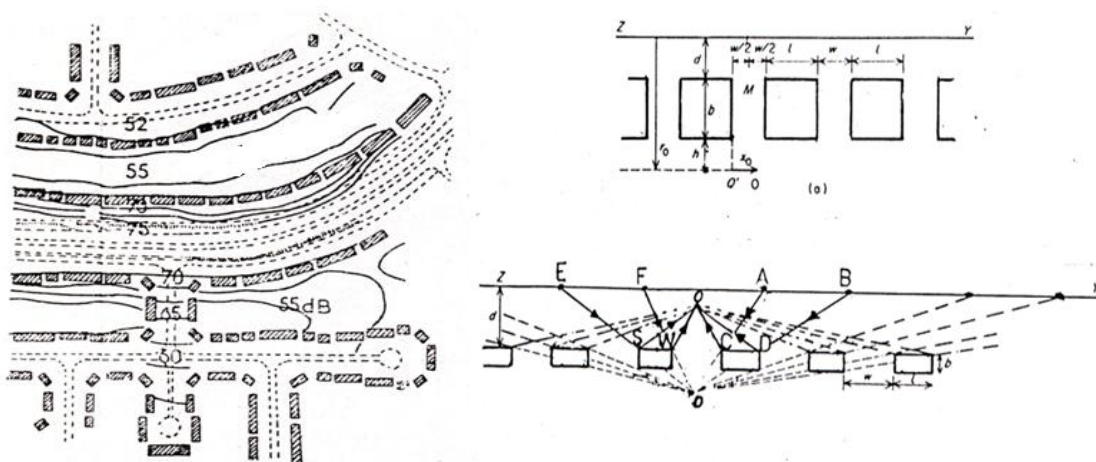

Figure (3): The gap between adjacent blocks (K.W.Yeow, 1978)

The less the number of gaps in a row with more block heights, the less the location's exposure to the source is. Thus, the noise attenuation value increases and reaches its highest value when the buildings are tight and compact, Figure (4).

The distance between a building and another in the same row must be less than the building width to reduce the gap between adjacent blocks; thus, avoid acoustical reflections between them, (K.W.Yeow, 1978).

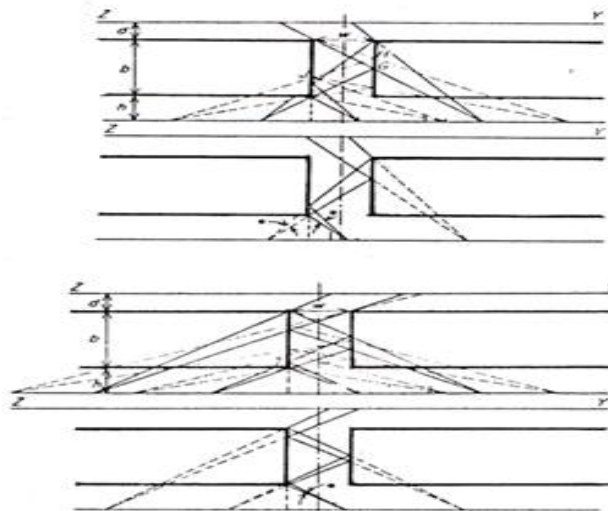

Figure (4) – Noise wave reflections and penetration through the gaps between buildings

When planning cities, parallelism in barrier building rows should be avoided in order to eliminate frequent reflections between their façades. Parallelism creates wind channels between the building rows which increase wind speed and

propagation that in turn help increasing sound propagation if they were in the same direction, Figure (5). Accordingly, the noise level will increase. (The State Government of NSW, 2008).

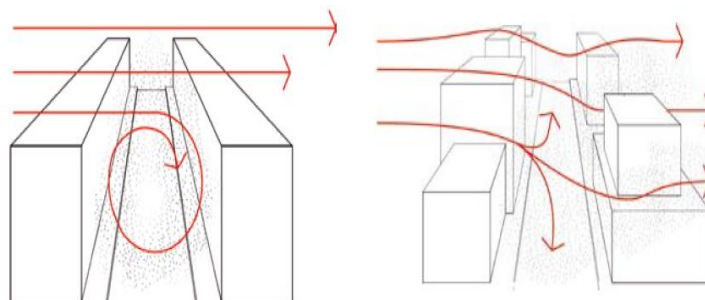

Figure (5) - Roadway canyons and their effect on winds and noise pollutants

Therefore, it is recommended to break the parallelism pattern by a staggered one, stepping back the upper storey of roadside in order to reduce the effect of air pollution and canyoning (wind noise) between high buildings near the street.

Continuous façades without surface changes such as terrace housing tend to cause noise to reverberate between the two façades. Road 'canyons' may channel winds or prevent them from reaching road level depending on their shape, dimension and orientation, (The State Government of NSW, 2008).

In order to avoid frequent sound reflections among high buildings which are parallel to each other, it is preferred to

be arranged in staggered elevation in accordance with the paths of the contour lines of noise spreading at the vertical section level, Figure (6), in addition to the horizontal staggering façades which will create visual access to act as a sound diffuser surfaces and to provide a noise shadow area behind buildings. (Dept. of Planning, Transport and Infrastructure, 2012).

In this case the line of sight between the building façade and the sound source may be interrupted and shielded by the edge of the road corridor or by the lower storey of the building itself.

In this aspect a harmony building heights with the contour lines of noise propagation from the street to the receiver site are needed.

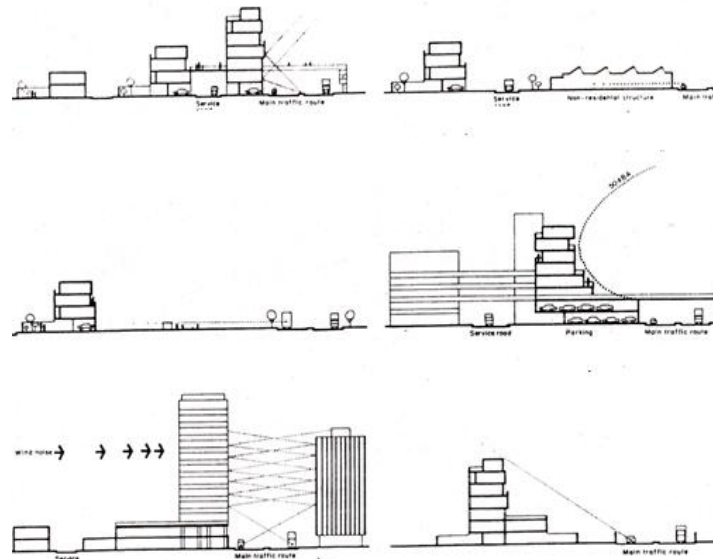

Figure (6)- Staggered elevation in accordance with the paths of the contour lines

On the other hand, the variables affecting noise attenuation in buildings grouping like clusters surrounding open spaces are as follows: (C.LAMURE, 1981).

1. Buildings shape and size configurations.
2. Spreading of reflected sound wave paths between buildings' façades and the impact of Angled buildings on sound reflection to other buildings at the back,

Figure (7). Thus; articulated façades and vegetation may help to diffuse the reflected sound waves. (Dept. of planning, NSW, 2008).

3. Barrier buildings' façades orientation; which affect open spaces direction towards the noise shadow area.
4. Increase of the percentage of protected/exposed area of buildings' facades surface facing the street.

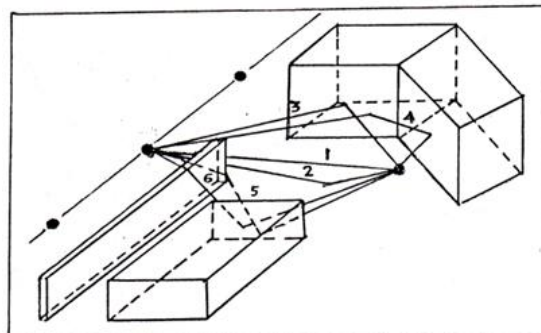
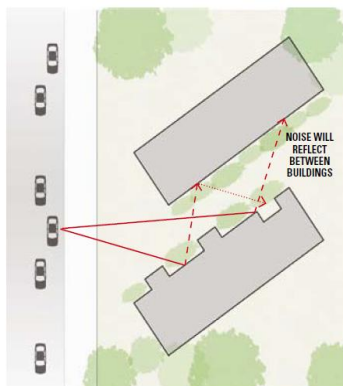

Figure (7) - Angled buildings can reflect sound back into other buildings

IV. COMPUTER SIMULATION OF MATHEMATICAL MODELS:

To test hypothesis considering the above stated, eight mathematical models are studied to represent several configuration types with different geometrical shapes of buildings facing the street (a linear source consisting of a set of point sources equidistant from each other) which function as a noise barrier between source and urban area facing the traffic noise. These buildings are located at the same distance from the source line.

Reception points (A,B,C) are located on the center line of the gap between these barrier blocks representing three locations of different distance from the source line, in order to study the impact of:

- a) The location of reception points (distance from the street) on noise attenuation.

- b) The gap's depth and the shape of the surrounding buildings' façades on the number and length of reflected sound paths.
- c) The length of the visual line of the source (street) from receiver locations, on the number and length of direct sound paths that affect the degree of traffic noise attenuation.

A. Hypothesis constants:

- The distance from the first row of buildings to the source line for all models
- The locations of reception points (A,B,C) from the source line
- The value of sound intensity at the source :- $I_s = 0.25 * 10^{-5}$
- The absorption coefficient of a barrier building façade:- $k=0.02$, with a frequency of 1000 Hz.
- Linear noise level:- $L_p = 75$ db

B. Hypothesis variables:

- The length of the visual part of the linear source (visual source).
- The number and length of direct noise paths from the set of points on the source line.
- The number and length of reflected noise paths from barrier buildings' façades on both sides of the gap.

C. Calculation of parameter values using geometrical analysis of models

1. Determine the visual angles from each reception point to the source line.
2. Calculate the length of direct sound paths from visual point of sound source line to the reception points inside building's gap (A, B, C), figure (8).

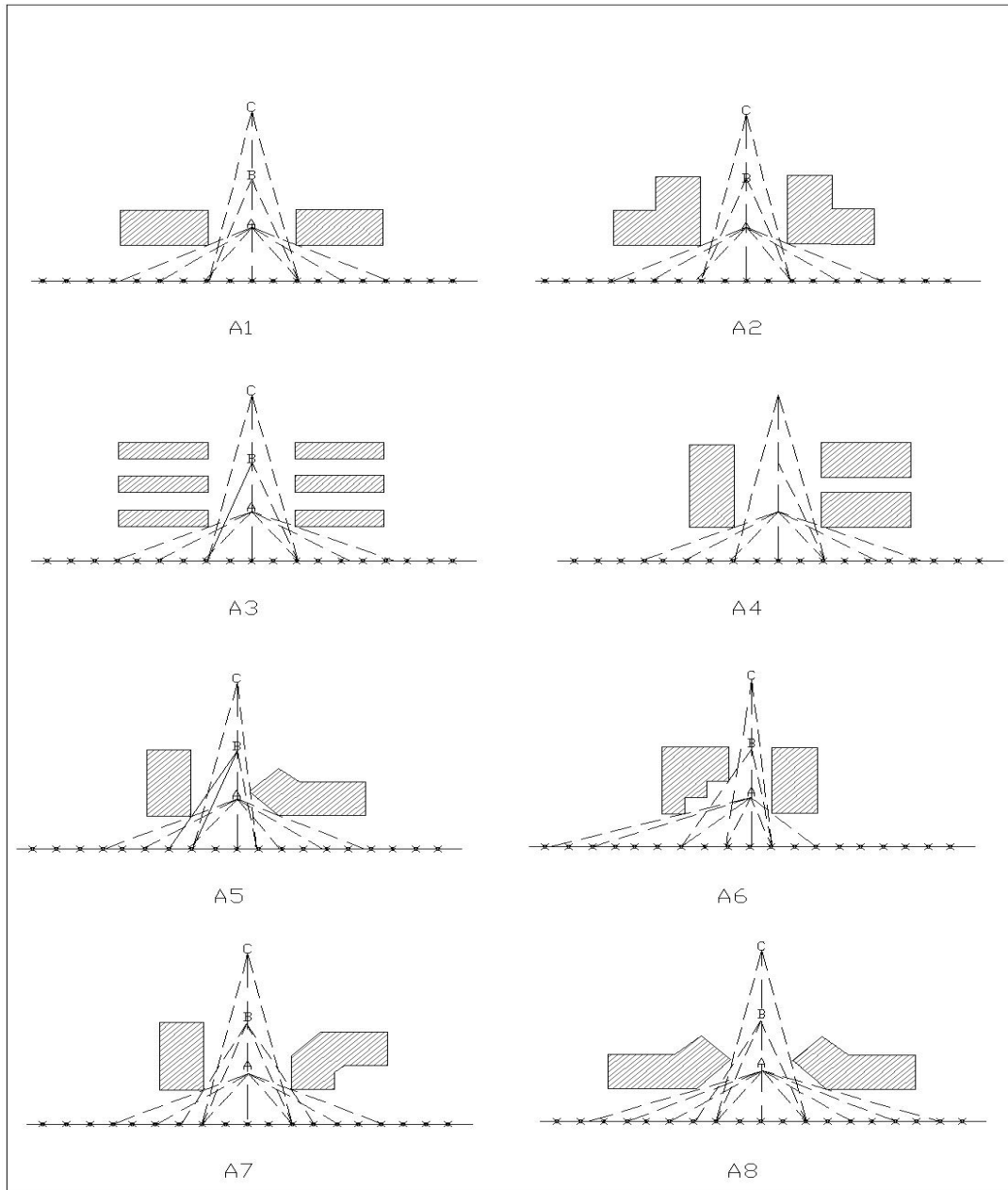

Figure (8) - mathematical models showing direct sound paths through the gap to reception points.

Figure (8) shows the effect of building's configuration of the mathematical model on direct sound paths and visual angles through the building's gap to reception points.

3. Determine the location of points reflecting incident sound on the sidewalls of barrier blocks located on both sides of the gaps by a reception point image method.
4. Calculate the length of incident and reflected sound paths to the reception points after determining the

coordinates of each of them with respect to the point of origin (0, 0), Figure (9).

- Coordinates of point sources that constitute the finite linear source by visual angles at different reception points.
- Coordinates of reception points (A, B, C).
- Coordinates of sound reflecting points at the barrier blocks' walls on both sides of the gap.

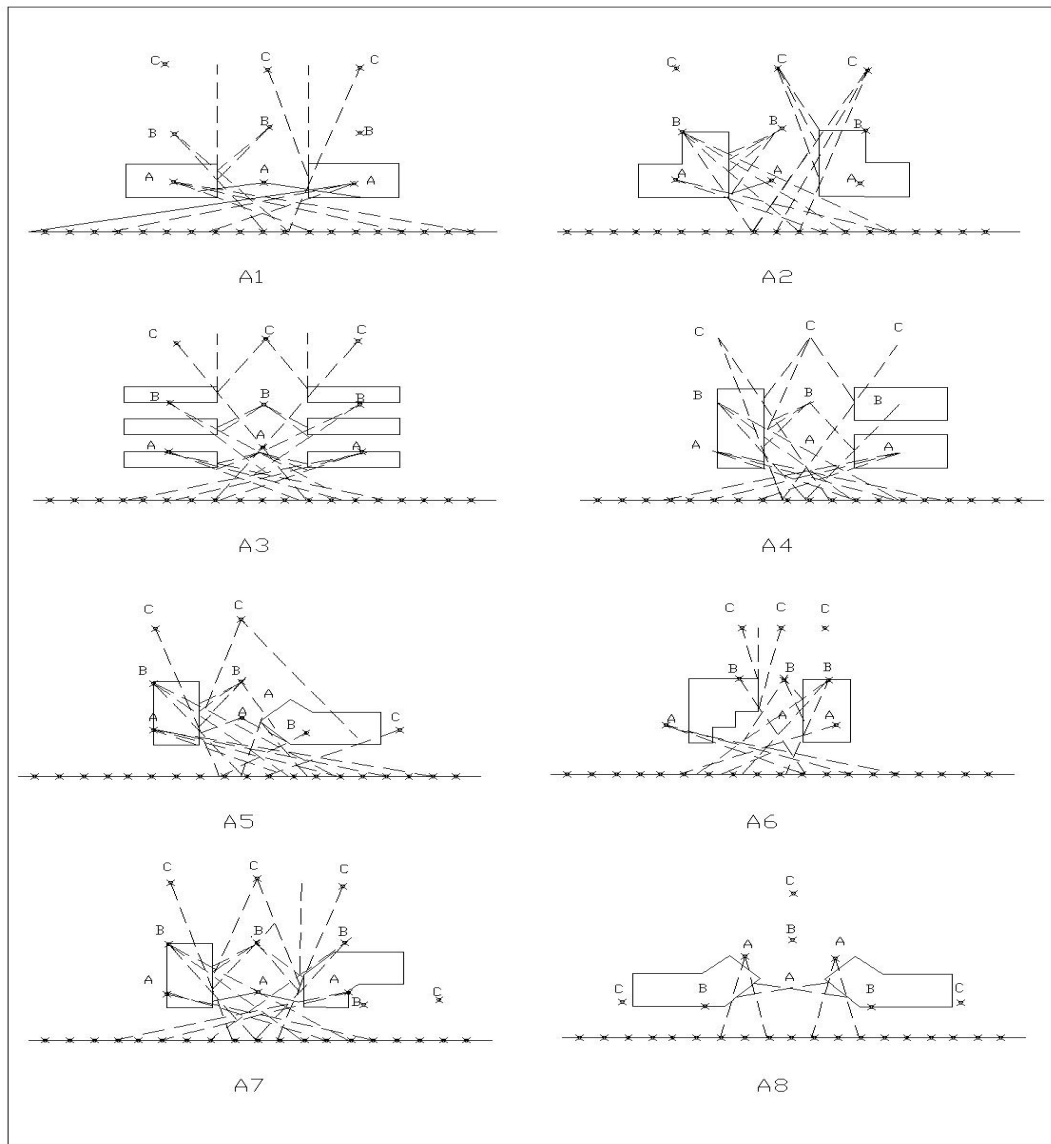

Figure (9) - Configuration types of the mathematical models showing reflected Sound paths From barrier buildings' façades to reception points.

D. Application of mathematical equations to find values of defined variables

The values of parameters resulting from geometrical analysis of mathematical models configuration types for barrier blocks are used to calculate the attenuation value at each reception point by using these equations:

1. Calculation of direct sound intensity, (I_D) (received from visual point sources that constitute the visual linear source) in every reception point (A, B, C). (Leo, L.Beraneck,2005)

$$I_D = \sum_{i=1}^n \left(\frac{I_s}{d_i^2} \right)$$

I_D = Direct Sound Intensity at each reception point (A, B, C).
 I_s = Sound Intensity at the source = $w/m^2 \cdot 10^{-5} \cdot 0.25$
 d = Distance from the visual part of the linear source to the reception point

2. Direct Sound Level at each reception point (A, B, C), (L_D) (Leo, L.Beraneck,2005)

$$L_D = 120 + 10 \log(I_D)$$

3. Reflected Sound Intensity (for a single visual point source), (I_R) at each reception point (A, B, C).

$$I_R = \frac{I_s(1-\alpha)}{(T)^2}$$

I_R = Reflected Sound Intensity at each reception point (A, B, C).

α = Absorption Coefficient for the building's façade = 0.02
 T = Total length of direct and reflected sound paths from the building

4. Reflected Sound Intensity of a set of visual point sources, (I_R) (Leo, L.Beraneck,2005)

$$I_R = \sum_{i=1}^n I_{R_i}$$

5. Reflected Sound Level, (L_R) . (Leo, L.Beraneck,2005)

$$L_R = 120 + 10 \log(I_R)$$

6. Total Received Sound Level, (L) (direct and reflected sound) at a reception point.

$$L = (L_D + L_R)$$

7. The Attenuation Value at each reception point

$$AT = L_P - L$$

L_P = Noise Level of the linear source =75 db

| Mode I No | Reception point - A | | | | Reception point - B | | | | Reception point - C | | | |
|----------------|---------------------|------------|-----------|------------|---------------------|------------|-----------|------------|---------------------|------------|-----------|------------|
| | LD(db) | LR(db) | L(db) | AT(db) | LD(db) | LR(db) | L(db) | AT(db) | LD(db) | LR(db) | L(db) | AT(db) |
| A ₁ | 36.18 | 29.39 | 65.57 | 9.4 | 29.85 | 29.31 | 59.2 | 15.8 | 25.6 | 23.53 | 49.1 | 25.8 |
| A ₂ | 36.18 | 29.39 | 65.57 | 9.4 | 29.85 | 31.53 | 61.4 | 13.6 | 25.6 | 28.02 | 53.7 | 21.3 |
| A ₃ | 36.18 | 29.39 | 65.57 | 9.4 | 29.85 | 27.6 | 57.5 | 17.5 | 25.6 | 22.51 | 48.1 | 26.8 |
| A ₄ | 36.18 | 29.39 | 65.57 | 9.4 | 29.85 | 28.8 | 58.7 | 16.34 | 25.6 | 24.88 | 50.5 | 24.51 |
| A ₅ | 36.18 | 33.12 | 69.31 | 5.6 | 28.92 | 27.18 | 65.1 | 18.89 | 23.88 | 20.52 | 44.4 | 30.5 |
| A ₆ | 35.66 | 32.23 | 67.89 | 7.1 | 28.92 | 29.91 | 58.1 | 16.8 | 23.52 | 23.72 | 47.3 | 27.7 |
| A ₇ | 36.18 | 29.39 | 65.57 | 9.4 | 29.85 | 29.68 | 59.6 | 15.4 | 25.62 | 23.5 | 49.1 | 25.8 |
| A ₈ | 46.16 | 23.72 | 69.88 | 5.1 | 29.85 | 0 | 29.9 | 45.12 | 25.61 | 0 | 25.6 | 49.38 |

Table (1) - Parameter values calculated from the program

LD=Direct sound level LR= Reflected sound level L= Total sound level

Table (1) above clarifies how the length of the visual line from the source and the number of direct and reflected sound paths affect the total received sound level at reception points (A,B,C) and thus causes a reduction of noise

attenuation. It is observed, however, that the smaller the gap's exposure degree to the source line is, the bigger its noise attenuation becomes. Figures 10 through 16 represent outcomes of the computer analysis, as follows:

E. Diagrammatic representation of results:

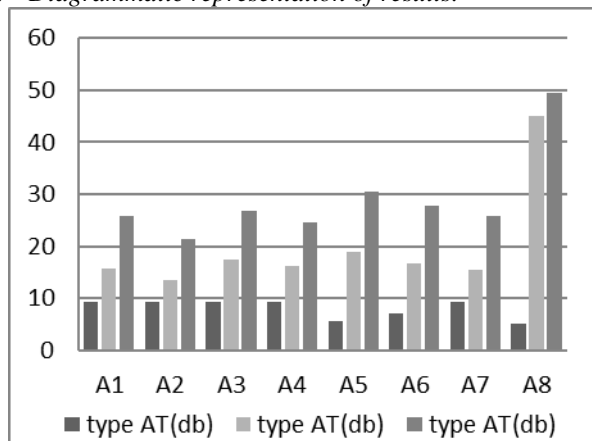

Fig (10)- Comparison between attenuation values(AT) for reception points (A,B,C) for all types.

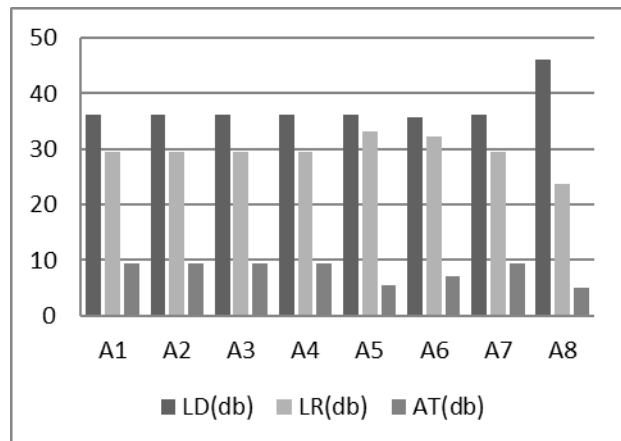

Fig (11)- Impact of direct(LD) and reflected sound Level (LR) on attenuation values (AT) for reception point (A)

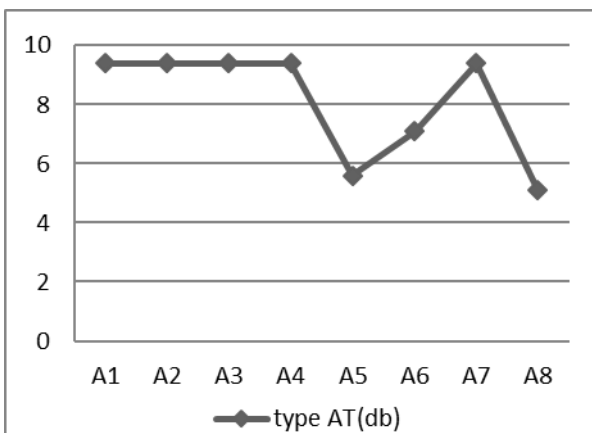

Fig (12)- Comparison between attenuation values for reception point (A) for all types.

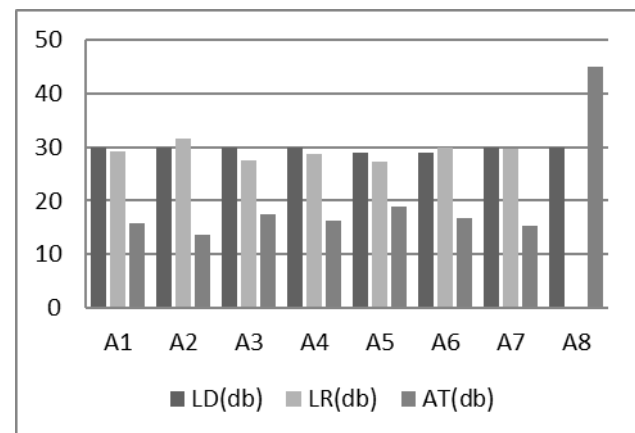

Fig (13)- Impact of direct (LD) and reflected sound level (LR) on attenuation values (AT) for reception point (B).

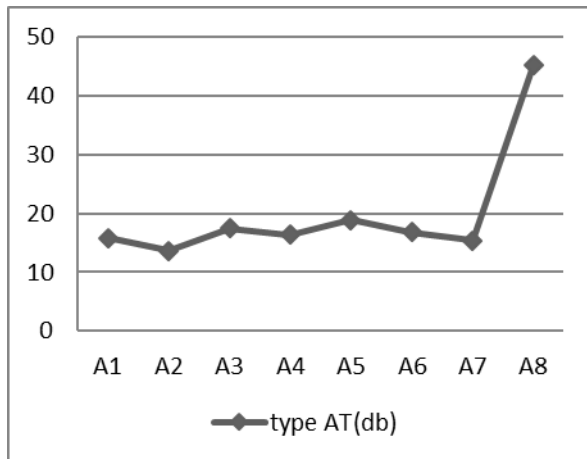

Fig (14)- Comparison between attenuation values for reception points (B) for configuration types

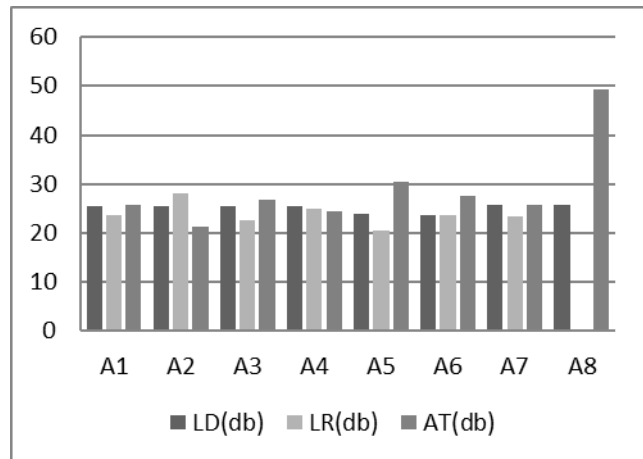

Fig (15)- Impact of direct(LD) and reflected sound level (LR) on attenuation values (AT) for reception point (C).

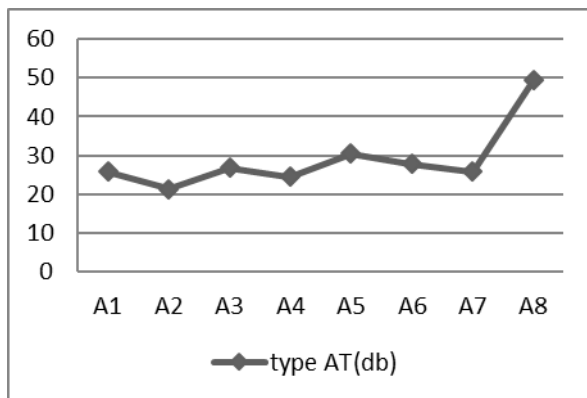

Fig (16)- Comparison between attenuation values for reception points (C) for all configuration types

V. CONCLUSIONS:

1. The configuration and orientation of the gap's sidewalls surface changes its exposure degree to the source. This limits the length of the visual line from the source and the number of direct sound paths affecting the total received sound level.
2. The attenuation value increases whenever the number and length of reflected sound paths decrease, with the constancy of the number of direct sound paths; i.e. the constancy of gap's exposure degree.
3. When comparing between attenuation values for reception points of different types, it was observed that the sound level was affected by the gap's exposure degree to the source according to buildings arrangement type, whereas the parallelism of the walls of the 2 blocks at the sides of the reception points (B, C) reduce the attenuation value, figure (14 and 16) type (A2, A4, A7) because of the increase in sound reflection, Figure (9). Moreover, the orientation in one of the two blocks or both increases the gap's exposure degree and the length of the visual line from the source which will reduce the attenuation value at reception point (A), figure (9 and 12) type (A8).
4. Staggered walls in one of the two buildings facing the sound source figure (9) - type (A6), result in larger attenuation at reception point (A) than if the walls have inclination on one side, figure (9 and 12) compare type

- (A6) with type (A5). The latter also results in higher attenuation than if the inclination is in both buildings, figure (9 and 12) compare type (A5) with type (A8).
5. Attenuation value of reception point C has the less value in comparison with the reception points (A,B) due to its distance from traffic noise, beside receiving less sound reflected paths from building side walls, figure (10).
6. Reflected sound level (LR) for each type of models was affected by the gap's exposure degree to the sound source which will reduce the noise attenuation value, figure (11).
7. The lowest attenuation at reception point (A) is for type (A8) due to gap's side walls inclination in both building which will increase gap's exposure to traffic noise, figure (12).
8. For reception point (B), the attenuation value in type (A1) is larger than the attenuation value in type (A2) because of the side wall reflecting sound wave at the sides of the gap, figure (13).
9. Side gaps reduce the number of reflected sound paths. Therefore, attenuation value in type (A3) and (A4) are larger than types (A1) and (A2) at reception point (B), figure (9). So, attenuation value increases with the existence of side gaps as in type (A3), figure (13).
10. Reception point (B) in type (A5) barely receive reflected sound paths from the walls that have inclination on one side which will increase the attenuation value at this

point compared to other types, except type (A₈). It has the highest attenuation values compared with other types, figure (13), since it does not receive reflected sound from side buildings which reduces the total received sound level. Thus, the attenuation value increases, figure (14).

11. The point (C) in type (A₆) receives reflected waves in a shorter path than it does in type (A₅) which reduce the attenuation value of this point as the attenuation increases when the reflected path is longer due to the loss of part of its sound energy with distance, figure (15).
12. At type (A₈), there are no reflected paths, as point (C) receives only direct sound which will give the highest attenuation, figure (16). However, point (C) has the lowest attenuation at type (A₂).

RECOMMENDATIONS

1. This study recommends avoiding continuity of solid sidewalls by opening side gaps which reduce the number of reflected sound wave paths or by creating irregular surfaces that shall disperse these sound waves.
2. The depth of the gap between barrier buildings shall be determined by geometrical analysis of the incident and reflected sound paths from surrounding building surfaces.
3. Reduction of the building's gap exposure to traffic noise can be achieved through using articulated configurations of building's façade to reflect the sound paths far away from building's gap which minimize the number of direct sound wave paths originating from traffic noise.

REFERENCES

- [1]. C.LAMURE; "The Annoyance due to Road Traffic Noise, The Mathematical Modelling of such Noise and The Sound Proofing of Road Vehicles", J. of sound & Vibration, 1981.
- [2]. Dept. of planning; "Development Near Rail Corridors and Busy Roads-Interim Guideline", The State Government of NSW, 2008.
- [3]. Dept. of Planning, Transport and Infrastructure; "Redacting Noise and Air Impact from Road, Rail and Mixed Land use", 2012.
- [4]. Dept. of Transport, Welsh office; "Calculation of Road Traffic Noise", Welsh Office HMSO, 1988.
- [5]. Egan, D.; "Architectural Acoustics", Mc Graw-Hill INC., 1988.
- [6]. Environmental Protection Department; "Guidelines on Design of Noise Barriers", Government of the Hong Kong SAR Second Issue, January 2003.
- [7]. Ervin H. Zube, Gary T. Moor, "Advances in Environmental Behavior and Design", Plenum Press, 1990.
- [8]. F. Kranendonk, L. Nijs; "The Prediction of Noise Level in Built-up Areas and Acoustical Guidelines for Town-Planning", Proceeding Noise-Control for The 80's, Inter-Noise, 1980.
- [9]. K.W.Yeow, J.F.W.Mackay; "Shielding of Noise from Statistically Stationary Traffic Flows by Simple Obstacles", 1978.
- [10]. Lara Sa'enz; R.W.B. Stephens; "Noise Pollution"; John Wiley & Sons; 1986.
- [11]. Leo L. Beranek, Istvan L. Ver; "Noise and Vibration Control Engineering", Wiley; 2005.
- [12]. Royl Richards Jan. H. Hange; "Acoustical Design of A condominium Project in A freeway Environment", Inter-Noise, 1984.
- [13]. Selma Kurra; "A Computer Model for Predicting Sound Attenuation by Barrier-Buildings"; Applied Acoustics, 1980.
- [14]. VIC Roads; "A Guide to the Reduction of Traffic Noise", VIC Road Publication, 2003.